

JARVIS

Machining Center Attachments

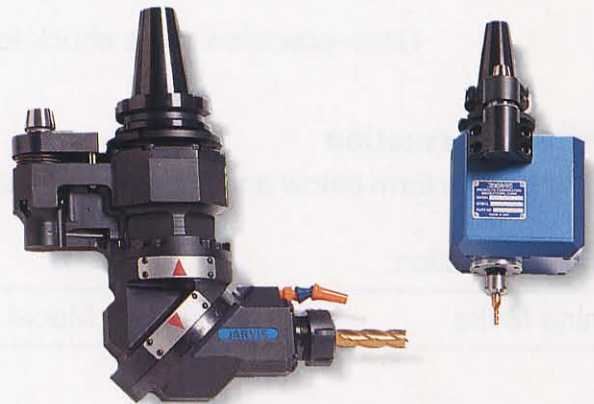

Standard Right Angle Heads



Variable Angle Head, Drill Speeder



Custom Tooling

MANUFACTURER OF HIGH-PRECISION MACHINE TOOL ATTACHMENTS

Jarvis Machining Center Attachments

Right Angle Head

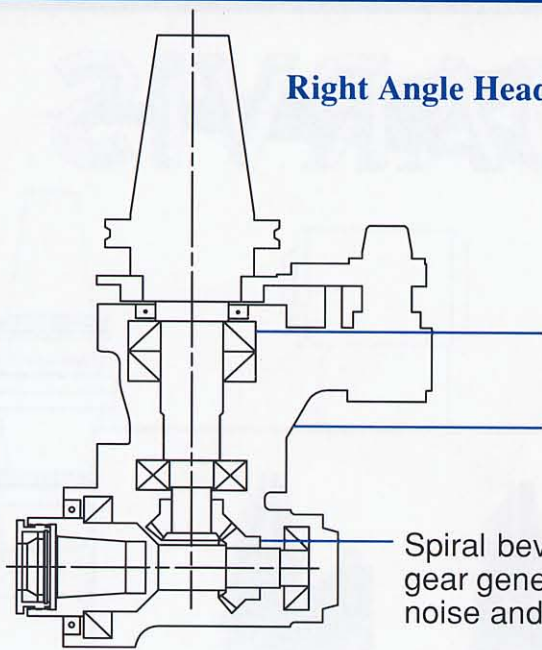

All bearings are super precision ABEC 7 rated for minimal runout and maximum rigidity.

Bodies are manufactured from investment cast 4340 alloy steel – heat-treated for strength and durability.

Spiral bevel gears are cut in-house on a CNC spiral bevel gear generator for an exact tooth form which results in lower noise and higher load carrying capacity.

Speeder

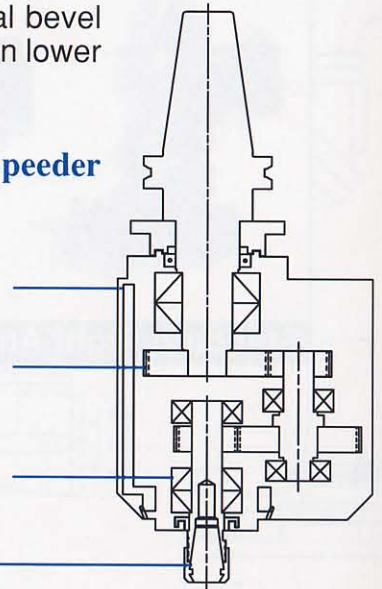

Coolant through the body allowing continuous high speed (25,000 RPM) operation.

Helical gears are precision ground after heat treating for smooth, quiet (4:1 or 6:1) operation.

All output shaft bearings are super precision ABEC 7 rated for minimal runout and maximum rigidity.

Ultra-precision collet chuck for accurate machining.

Ordering Information

Please fill out the form below and forward your inquiry to Jarvis Products Corporation for a detailed quotation.

General Information:

Machine Make	Machine Model	Tool Type (Right Angle Head, Speeder, etc.)

Tool Information:

Shank Style (CAT40, BT50, etc.)	Collet Style (ER, TG, DA, etc.)	Max. Cutting Tool Size

JARVIS

Manufacturer of high precision machine tool attachments

Jarvis Products Corporation • 33 Anderson Road • Middletown, CT 06457 • United States of America
 Telephone (860) 347-7271 • Fax (860) 347-6978